

TECHNICAL NOTE – RL2400S

CABLING AN RL-2400S TO NATIONAL INSTRUMENT’S FIELDPOINT DISTRIBUTED I/O

Objective: The following note describes how to interface National Instrument’s FieldPoint (FP-1000) I/O system with the RL-2400S radio modems. The RL-2400S radio modems can be configured as a Point-to-Point or a Point-Multipoint (broadcast) network and be transparent to the FieldPoint I/O system. If a single PC is communicating with a single FieldPoint (FP-1000) module, the RL-2400S can be configured as a point-to-point network. If a single PC is connected to multiple FieldPoint (FP-1000) modules, then the RL-2400S radio modem is configured as a point-multipoint network.

Cable Configuration to the FP-1000 Network Module

The following hardware was used to cable the RL-2400S radio modem to the FieldPoint (FP-1000) network module:

- FP-1000 - RS232 Network Module
- FP-AO-200 - 8-Channel Current Output Module
- FP-DO-410 - 16-Channel Discrete Output Module
- Power Supply and Accessories (DB9 standard serial cable & DB9 null modem cable)

The following are the cable configurations needed to communicate from the PC to the FieldPoint FP-1000 network module. The cable connection from the PC running FieldPoint Explorer to the Master RL-2400S radio modem is a standard, straight through, DB-9 pin serial cable. A null modem cable is needed to connect the FieldPoint FP-1000 to a remote RL-2400S radio modem. Also shown is the pin-out for the null modem cable used in this application.

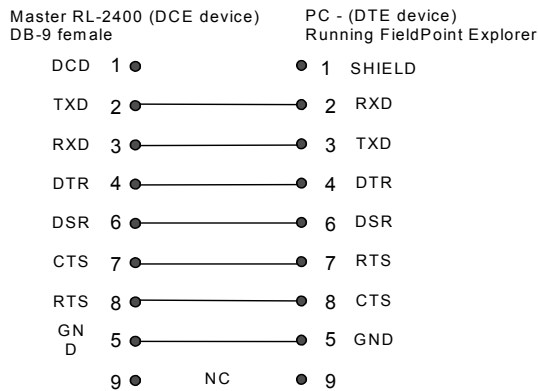

Standard Serial Cable

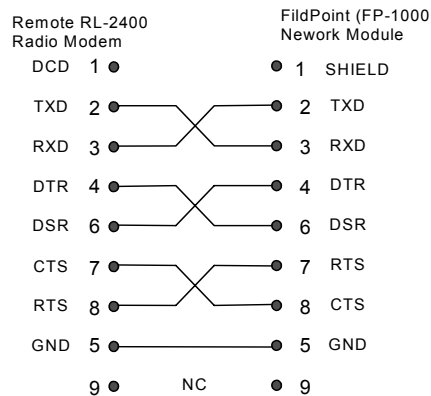

Null Modem Cable

The diagram represents a transparent wireless RL-2400S point-to-point network communicating with NI’s FieldPoint Distributed I/O.

TECHNICAL NOTE – RL2400S

CABLING AN RL-2400S TO NATIONAL INSTRUMENT'S FIELDPOINT DISTRIBUTED I/O

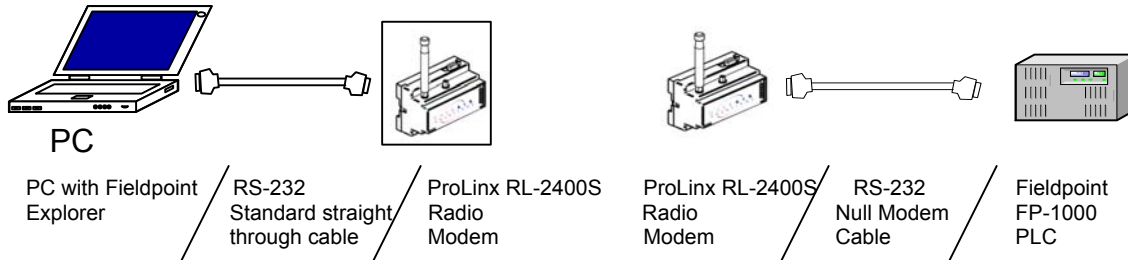

Configuring the RL-2400S Radio Modem Settings

The RL-2400S radio modems can be configured as a Point-to-Point or a Point-Multipoint (broadcast) network and be transparent to the FieldPoint I/O system. If a single PC is communicating with a single FieldPoint (FP-1000) module, the RL-2400S can be configured as a point-to-point network. If a single PC is connected to multiple FieldPoint (FP-1000) modules, then the RL-2400S radio modem is configured as a point-multipoint network.

The following radio settings will help insure that the radio will communicate to the FieldPoint FP-1000 Network module:

- Baud Rate - 9600
- Data Bits - 8
- Parity - None
- Stop Bits - 1
- Hardware - None (hardware handshaking)

Configuring the FieldPoint Software to Communicate with the RL-2400S Radio Modem

Download the FieldPoint driver software and configure the modules using the FieldPoint Explorer software. Follow the steps below to set the FieldPoint communication parameters.

- Expand the IA Server OPC directory to show the FieldPoint directory
- Highlight the FieldPoint directory:
 - Right click mouse and select "add comm resource to this server"
- Set the following inside the Comm Resource configuration screen:
 - Device Name
 - Type of communication – (RS232/485)
 - Attributes – make sure the FieldPoint communications (baud rate) match the RL-2400S radio settings
 - Change time out settings from 100msec to 150msec
 - Click on <Find Devices> button
- The software will poll the hardware to determine the hardware configuration on the network (module type and I/O configuration).
- Once communications have been established, each of the I/O modules can be monitored:
 - Select "start monitoring" from the toolbar (green > arrow) or from I/O menu.
 - Expand the I/O module directory; the channels associated with that module will appear (i.e. channel 0 – channel 7).
 - The Boolean values for each module can be manually changed. Once the new value for the specified channel is changed, the LED for that channel will change.